

Borough of

New Stanton, Pennsylvania

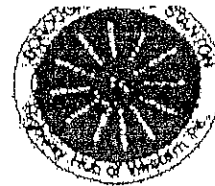

Phone: 724-925-9700
Fax: 724-925-2709
e-Mail: boroughofnewstanton@verizon.net

451 North Center Ave,
New Stanton, PA 15672

PERMIT APPLICATION FOR ACCESSORY STRUCTURES & MISCELLANEOUS CHANGES TO EXISTING STRUCTURES

Application Date _____ Application Number _____

Name of Applicant _____ Phone Number _____

Address _____
Street & Number City State Zip Code

Application is hereby made to:

Use Erect Repair Alter Extend Remove Demolish Change use of
A structure or land located at _____ Borough of New Stanton for:

Residence Commercial Business Accessory Building Industry Other

at an estimated cost of \$ _____

The following description of the use for this property, for which application is made herewith, is submitted: _____

Area zoned (as of this date) _____ Tax Map No _____

Use for which application is made is: Permitted Special Exception Conditional

A plot plan is attached is not attached Floor plans are included are not

Plans have have not been approved by the Pennsylvania Department of Labor

Disposition of Application Approved Denied

If denied, state Ordinance number or name, article, section, subsection, paragraph on which denial of application is based.

STATEMENT OF APPLICANT: I do hereby agree to observe and adhere to any and all provisions of the Zoning Ordinance and Building Code of the Borough of New Stanton, Pennsylvania, where applicable under the issuance of this Building or Zoning Permit. And I do further agree that my failure to do so shall constitute a violation of this Permit, which Violation shall cause this Permit to become Null and Void, upon receipt of notification to that effect, in writing, from the Code Enforcement Officer or other Duly Authorized Agent of the Borough of New Stanton, Pennsylvania.

Owner Signature _____

Agent of Owner _____

Permit Fee _____

Date Issued _____

Payment Received _____

Signature

Title

Permit Issued by _____

Signature

Title

New Stanton Borough **BUILDING PERMIT APPLICATION**

Both sides of application to be completed

APPLICANT		
NAME _____		
ADDRESS _____		
CITY _____	STATE _____	ZIP _____
PHONE () _____		
ALTERNATE PHONE () _____		CELL PHONE () _____
FAX () _____		PAGER () _____

OWNER (IF SAME AS APPLICANT CHECK <input type="checkbox"/>)		
NAME _____		
ADDRESS _____		
CITY _____	STATE _____	ZIP _____
PHONE () _____		
ALTERNATE PHONE () _____		CELL PHONE () _____
FAX () _____		PAGER () _____

CONTRACTOR (IF SAME AS APPLICANT CHECK <input type="checkbox"/>)		
NAME _____		
ADDRESS _____		
CITY _____	STATE _____	ZIP _____
PHONE () _____		
ALTERNATE PHONE () _____		CELL PHONE () _____
FAX () _____		PAGER () _____

LOCATION		
PROPERTY LOCATED AT _____	CITY _____	ZIP _____
BETWEEN _____	AND _____	
(Cross Street)	(Cross Street)	
SUBDIVISION _____	PARCEL # _____	ZONING _____
TAX MAP # 09- _____ - _____ - _____	SIZE OF LOT _____	
DEED BOOK _____	VOLUME _____	OWNED SINCE _____

<u>TYPE OF SEWAGE</u>		<u>TYPE OF WATER</u>	
<input type="checkbox"/> ON LOT		<input type="checkbox"/> PRIVATE	
<input type="checkbox"/> PUBLIC		<input type="checkbox"/> PUBLIC	
<input type="checkbox"/> NOT APPLICABLE		<input type="checkbox"/> NOT APPLICABLE	
SEWAGE VERIFICATION REQUIRED AT TIME OF BUILDING PERMIT ISSUANCE			

PROJECT DESCRIPTION

RESIDENTIAL

- 01 HOUSE
- 02 ADDITION
- 03 REMODELING
- 04 GARAGE
- 05 PORCH, PATIO, DECK
- 06 SWIMMING POOL
- 07 SHED OR STORAGE

COMMERICAL (BUSINESS)

- 10 BUILDING
- 11 ADDITION
- 12 REMODLING

(INDUSTRIAL)

- 20 BUILDING
- 21 ADDITION
- 22 REMODELING

OTHER

- 60 CELL TOWER
- 60 TANK
- 60 MISC. (DESCRIBE) _____
- 60 EXEMPT BUILDING _____
- 70 DEMOLITION

COST OF IMPROVEMENT _____	BUILDING MEASUREMENTS
	Length _____
	Width _____
	Height _____
SQUARE FOOTAGE OF PROPOSED STRUCTURE	
BASEMENT	_____
1 ST FLOOR	_____
2 ND FLOOR	_____
DECK	_____
GARAGE	_____
OTHER ENCLOSED AREAS	_____
TOTAL	_____

IN ADDITION TO THIS APPLICATION THE FOLLOWING IS REQUIRED

- _____ PLOT PLAN (must match building plans for proposed structure)
- _____ Two complete sets of building plans
- _____ Copy of Deed for property
- _____ Copy of Workers Compensation Insurance (If applicable)
- _____ **PA ONE CALL** serial # _____
(1-800-242-1776)

Building permit fee is to be paid when permit is issued

Applications that are incomplete or that do not contain all the requested information will be rejected until the requested information or documentation is received.

We require a 24 hr. notice on all inspections.

For an inspection please call (724)493-7793 daytime (724)468-0475 evenings Inspections can only be performed after 5:00 Pm on weekdays and on weekends. Mike Stack Building Inspector

 Signature of Person Completing This Form

DATE ____ / ____ / ____



Date Received
Date Issued
Control #
Permit #

BUILDING SUBCODE TECHNICAL SECTION

A. IDENTIFICATION—APPLICANT: COMPLETE ALL APPLICABLE INFORMATION. WHEN CHANGING CONTRACTORS, NOTIFY THIS OFFICE.

Block _____ Lot _____
 Work Site Location _____
 Owner in Fee _____
 Address _____
 Tele. (_____) _____
 Contractor _____
 Address _____
 Tele. (_____) _____ Fax (_____) _____
 Lic. No. or Bldrs. Reg. No. _____
 Federal Emp. No. _____

D. TECHNICAL SITE DATA

DESCRIPTION OF WORK

JOB SUMMARY (Office Use Only)

PLAN REVIEW	Date	Initial	INSPECTIONS	Dates (Month/Day)	Initial
<input type="checkbox"/> No Plans Required	_____	_____	Type: _____	Failure	Approval
<input type="checkbox"/> All	_____	_____	Footing	_____	_____
<input type="checkbox"/> Footing	_____	_____	Foundation	_____	_____
<input type="checkbox"/> Foundation	_____	_____	Slab	_____	_____
<input type="checkbox"/> Frame	_____	_____	Frame	_____	_____
<input type="checkbox"/> Other	_____	_____	Barrier-Free	_____	_____
Joint Plan Review Required:	_____	_____	Insulation	_____	_____
<input type="checkbox"/> Elec. <input type="checkbox"/> Plumb. <input type="checkbox"/> Fire <input type="checkbox"/> Elevator	_____	_____	Finishes	_____	_____
SUBCODE APPROVAL	_____	_____	Energy	_____	_____
<input type="checkbox"/> CO <input type="checkbox"/> CCO <input type="checkbox"/> CA	_____	_____	Mechanical	_____	_____
Date: _____	_____	_____	TCO	_____	_____
Approved by: _____	_____	_____	Other	_____	_____
_____	_____	_____	Final	_____	_____
_____	_____	_____	Barrier-Free	_____	_____

TYPE OF WORK:

New Building
 Addition
 Alteration
 Roofing
 Siding
 Fence
 Sign
 Pool
 Asbestos Abatement
 Lead Haz. Abatement
 Other _____

Height (exceeds 6') _____ Sq. Ft. _____

Demolition

FEE (Office Use Only)

Administrative Surcharge \$ _____
 Minimum Fee \$ _____
 Fee \$ _____
TOTAL FEE \$ _____

B. BUILDING CHARACTERISTICS

Use Group Present _____ Proposed _____
 Constr. Class Present _____ Proposed _____
 No. of Stories _____
 Height of Structure _____ Ft.
 Area — Largest Floor _____ Sq. Ft.
 New Bldg. Area/All Floors _____ Sq. Ft.
 Volume of New Structure _____ Cu. Ft.
 Total Land Area Disturbed _____ Sq. Ft.

Est. Cost of Bldg. Work:

1. New Bldg. \$ _____
 2. Alteration \$ _____
 3. Total (1+2) \$ _____

C. CERTIFICATION IN LIEU OF OATH
 I hereby certify that I am the (agent of) owner of record and am authorized to make this application.

Signature _____

1 White = Inspector Copy
 2 Canary = Office Copy
 3 Pink = Office Copy
 4 Gold = Applicant Copy

Design for Code Acceptance

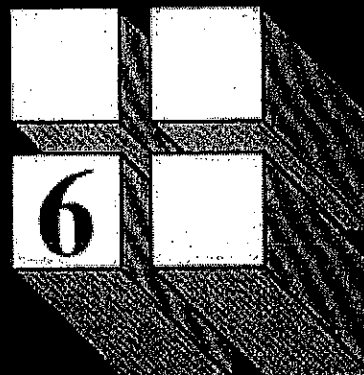

Prescriptive Residential Wood Deck Construction Guide

Based on the *2009 International Residential Code*

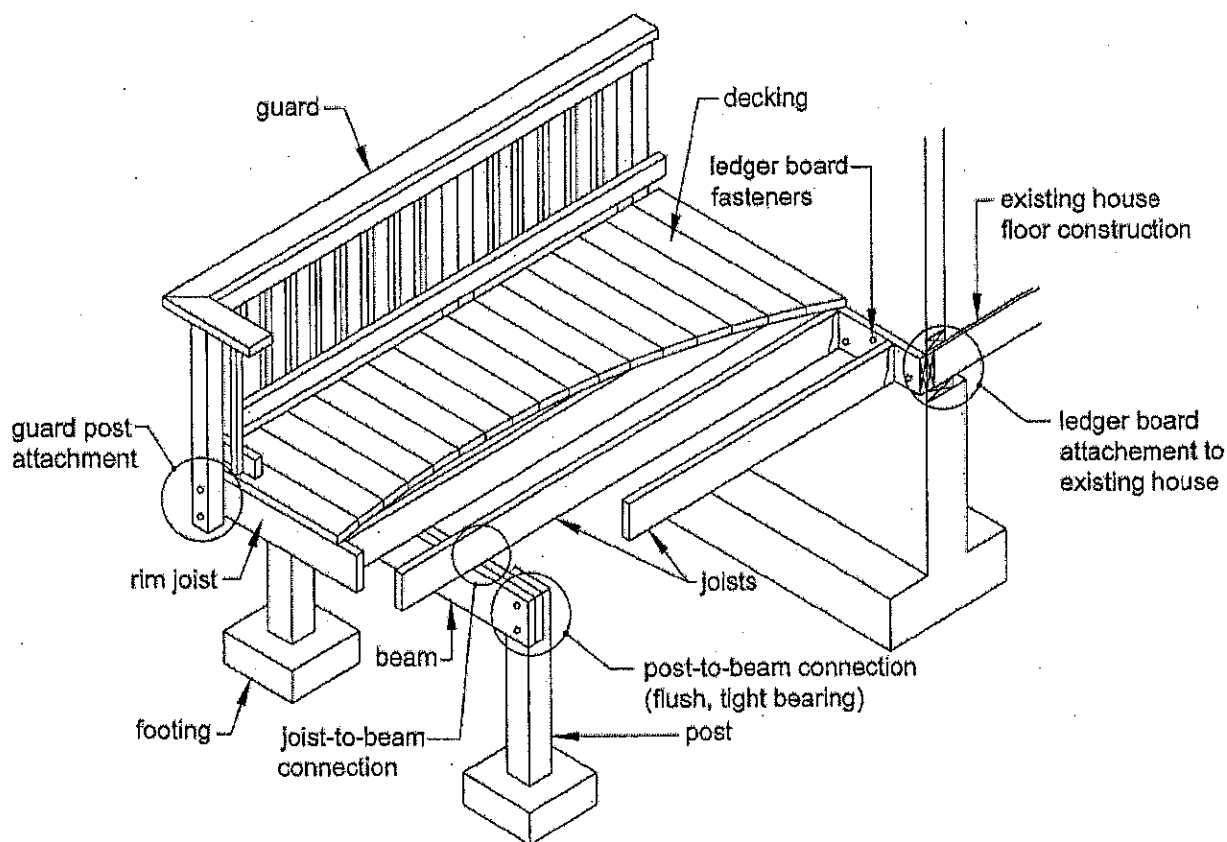

Where applicable, provisions and details contained in this document are based on the *International Residential Code (IRC)* [bracketed text references applicable sections of the *IRC*]. Prescriptive construction methods recommended meet or exceed minimum requirements of the *IRC*. Provisions that are not found in the *IRC* are recommended as good industry practice. Where differences exist between provisions of this document and the *IRC*, provisions of the *IRC* shall apply. This document is not intended to preclude the use of other construction methods or materials. All construction and materials must be approved by the authority having jurisdiction. Every effort has been made to reflect the language and intent of the *IRC*. However, no assurance can be given that designs and construction made in accordance with this document meet the requirements of any particular jurisdiction.

Table 1. Common preservative treatments and retention levels (pcf) for sawn lumber in ground contact.^a

Species	ACQ-B	ACQ-C	ACQ-D	CA-B	CuN-W
Southern Pine	0.40	0.40	0.40	0.21	0.11
Douglas Fir-Larch	0.40	0.40	NR	0.21	0.11
Hem-Fir	0.40	0.40	0.40	0.21	0.11
Ponderosa Pine	0.40	0.40	0.40	0.21	0.11
Red Pine	0.40	0.40	0.40	0.21	0.11
Spruce-Pine-Fir	NR	0.40	NR	NR	NR
Redwood	NR	NR	NR	NR	NR

^a Preservatives and retentions listed in Table 1 are based on the American Wood Protection Association (AWPA) *Book of Standards*. NR = Treatments Not Recommended.

DECKING REQUIREMENTS

All decking material shall be composed of dimension lumber (2" nominal thickness) or span rated decking in accordance with the American Lumber Standard Committee *Policy for Evaluation of Recommended Spans for Span Rated Decking Products (November 5, 2004)*. Attach decking to each joist with 2-8d threaded nails or 2-#8 screws. Space decking boards approximately 1/8" apart. See Figure 11 for decking connection requirements at the rim joist. Decking may be placed from an angle perpendicular to the joists to an angle of 45 degrees to the joists. Each segment of decking must bear on a minimum of 4 joists (or 4 supports).

Decking not meeting these requirements may be substituted when the product has been approved by the authority having jurisdiction.

JOIST SIZE

The span of a joist is measured from the centerline of bearing at one end of the joist to the centerline of bearing at the other end of the joist and does not include the length of the overhangs. Use Table 2 to determine joist span based on lumber size and joist spacing. See Figure 1 and Figure 2 for joist span types.

Table 2. Maximum Joist Spans (L_j)

Species	Size	Joist Spacing (o.c.)					
		Without Overhangs ¹			With Overhangs up to L _j /4 ²		
		12"	16"	24"	12"	16"	24"
Southern Pine	2x8	13' - 8"	12' - 5"	10' - 2"	10' - 9"	10' - 9"	10' - 2"
	2x10	17' - 5"	15' - 10"	13' - 1"	15' - 6"	15' - 6"	13' - 1"
	2x12	18' - 0"	18' - 0"	15' - 5"	18' - 0"	18' - 0"	15' - 5"
Douglas Fir-Larch, Hem-Fir, SPF ³	2x8	12' - 6"	11' - 1"	9' - 1"	9' - 5"	9' - 5"	9' - 1"
	2x10	15' - 8"	13' - 7"	11' - 1"	13' - 7"	13' - 7"	11' - 1"
	2x12	18' - 0"	15' - 9"	12' - 10"	18' - 0"	15' - 9"	12' - 10"
Redwood, Western Cedars, Ponderosa Pine ⁴ , Red Pine ⁴	2x8	11' - 8"	10' - 7"	8' - 8"	8' - 6"	8' - 6"	8' - 6"
	2x10	14' - 11"	13' - 0"	10' - 7"	12' - 3"	12' - 3"	10' - 7"
	2x12	17' - 5"	15' - 1"	12' - 4"	16' - 5"	15' - 1"	12' - 4"

1. Assumes 40 psf live load, 10 psf dead load, L/360 deflection, No. 2 grade, and wet service conditions. See Figure 1B.
2. Assumes 40 psf live load, 10 psf dead load, L/180 cantilever deflection with 220 lb point load, No. 2 grade, and wet service conditions. See Figure 1A and Figure 2.
3. Incising assumed for refractory species including Douglas fir-larch, hem-fir, and spruce-pine-fir.
4. Design values based on northern species with no incising assumed.

BEAM SIZE & ASSEMBLY REQUIREMENTS

Deck beam spans shall be in accordance with Table 3 and can extend past the post centerline up to $L_B/4$ as shown in Figure 3. Joists may bear on the beam and extend past the beam centerline up to $L_J/4$ as shown in Figures 1A and 2, or the joists may attach to the side of the beam with joist hangers as shown in Figure 1B.

Joists shall not frame in from opposite sides of the same beam. See JOIST-TO-BEAM CONNECTION details, Figure 6.

Where multiple 2x members are used, the deck's beam is assembled by attaching the members identified in Table 3 in accordance with Figure 4. [Table R602.3(1)]

Table 3. Deck Beam Spans (L_B)¹ for Joists Framing from One Side Only

Species	Size ⁴	Joist Spans (L_J) Less Than or Equal to:						
		6'	8'	10'	12'	14'	16'	18'
Southern Pine	2-2x6	7' - 1"	6' - 2"	5' - 6"	5' - 0"	4' - 8"	4' - 4"	4' - 1"
	2-2x8	9' - 2"	7' - 11"	7' - 1"	6' - 6"	6' - 0"	5' - 7"	5' - 3"
	2-2x10	11' - 10"	10' - 3"	9' - 2"	8' - 5"	7' - 9"	7' - 3"	6' - 10"
	2-2x12	13' - 11"	12' - 0"	10' - 9"	9' - 10"	9' - 1"	8' - 6"	8' - 0"
	3-2x6	8' - 7"	7' - 8"	6' - 11"	6' - 3"	5' - 10"	5' - 5"	5' - 2"
	3-2x8	11' - 4"	9' - 11"	8' - 11"	8' - 1"	7' - 6"	7' - 0"	6' - 7"
	3-2x10	14' - 5"	12' - 10"	11' - 6"	10' - 6"	9' - 9"	9' - 1"	8' - 7"
	3-2x12	17' - 5"	15' - 1"	13' - 6"	12' - 4"	11' - 5"	10' - 8"	10' - 1"
Douglas Fir-Larch ² , Hem-Fir ² , SPF ² , Redwood, Western Cedars, Ponderosa Pine ³ , Red Pine ³	3x6 or 2-2x6	5' - 5"	4' - 8"	4' - 2"	3' - 10"	3' - 6"	3' - 1"	2' - 9"
	3x8 or 2-2x8	6' - 10"	5' - 11"	5' - 4"	4' - 10"	4' - 6"	4' - 1"	3' - 8"
	3x10 or 2-2x10	8' - 4"	7' - 3"	6' - 6"	5' - 11"	5' - 6"	5' - 1"	4' - 8"
	3x12 or 2-2x12	9' - 8"	8' - 5"	7' - 6"	6' - 10"	6' - 4"	5' - 11"	5' - 7"
	4x6	6' - 5"	5' - 6"	4' - 11"	4' - 6"	4' - 2"	3' - 11"	3' - 8"
	4x8	8' - 5"	7' - 3"	6' - 6"	5' - 11"	5' - 6"	5' - 2"	4' - 10"
	4x10	9' - 11"	8' - 7"	7' - 8"	7' - 0"	6' - 6"	6' - 1"	5' - 8"
	4x12	11' - 5"	9' - 11"	8' - 10"	8' - 1"	7' - 6"	7' - 0"	6' - 7"
	3-2x6	7' - 4"	6' - 8"	6' - 0"	5' - 6"	5' - 1"	4' - 9"	4' - 6"
	3-2x8	9' - 8"	8' - 6"	7' - 7"	6' - 11"	6' - 5"	6' - 0"	5' - 8"
3-2x10	12' - 0"	10' - 5"	9' - 4"	8' - 6"	7' - 10"	7' - 4"	6' - 11"	
3-2x12	13' - 11"	12' - 1"	10' - 9"	9' - 10"	9' - 1"	8' - 6"	8' - 1"	

1. Assumes 40 psf live load, 10 psf dead load, $L/360$ simple span beam deflection limit, $L/180$ cantilever deflection limit, No. 2 grade, and wet service conditions.
2. Incising assumed for refractory species including Douglas fir-larch, hem-fir, and spruce-pine-fir.
3. Design values based on northern species with no incising assumed.
4. Beam depth must be equal to or greater than joist depth if joist hangers are used (see Figure 6, Option 3).

Figure 3: Beam Span Types

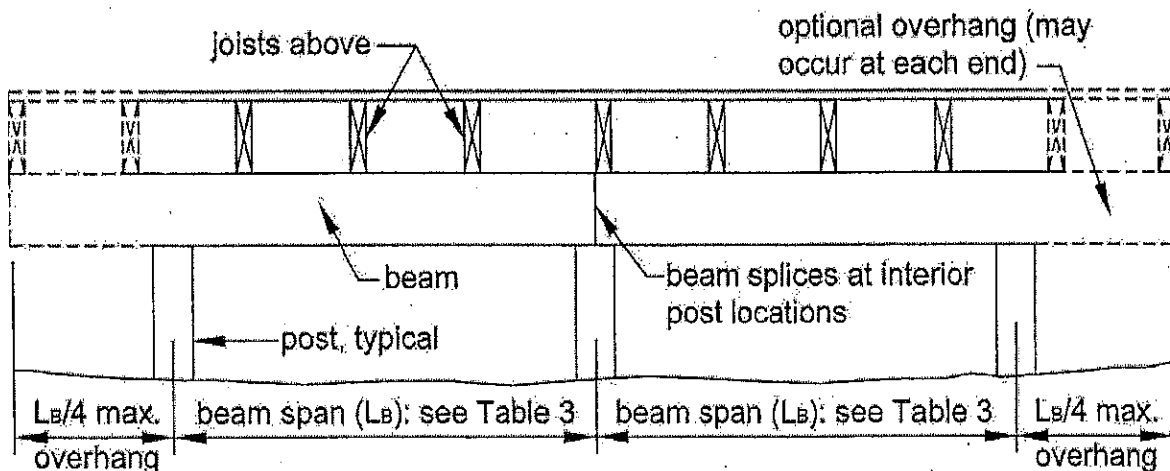

JOIST-TO-BEAM CONNECTION

Each joist shall be attached to the beam as shown in Figure 6. Joists may bear on and overhang past the beam a maximum of $L_j/4$. Use Option 1 or Option 2 to attach the joist to the beam. Option 1 shall only be used if the deck is attached to the house with a ledger (see LEDGER ATTACHMENT REQUIREMENTS) or as shown in Figure 23. Mechanical fasteners or hurricane

clips used as shown in Option 2 must have a minimum capacity of 100 lbs in both uplift and lateral load directions. Joists may also attach to the side of the beam with joist hangers per Option 3. Joists shall not frame in from opposite sides of the same beam. See JOIST HANGERS for more information. Hangers, clips, and mechanical fasteners shall be galvanized or stainless steel (see MINIMUM REQUIREMENTS).

Figure 6: Joist-to-Beam Detail

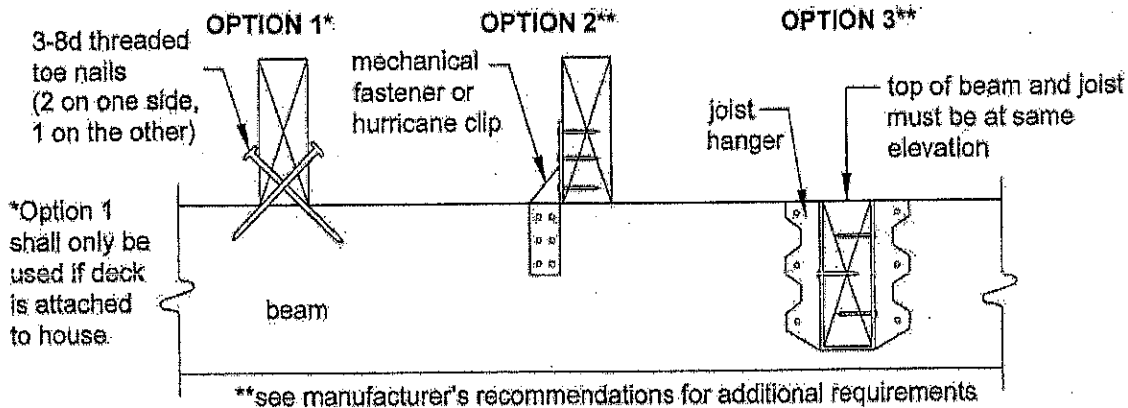

JOIST HANGERS

Joist hangers, as shown in Figure 7, shall each have a minimum download capacity in accordance with Table 3A. The joist hanger shall be selected from an approved manufacturer's product data based on the dimensions of the joist or header it is carrying. Joist hangers shall be galvanized or stainless steel (see MINIMUM REQUIREMENTS).

Use joist hangers with inside flanges when clearances to the edge of the beam or ledger board dictate. **Do not use clip angles or brackets to support joists.**

Figure 7: Typical Joist Hangers

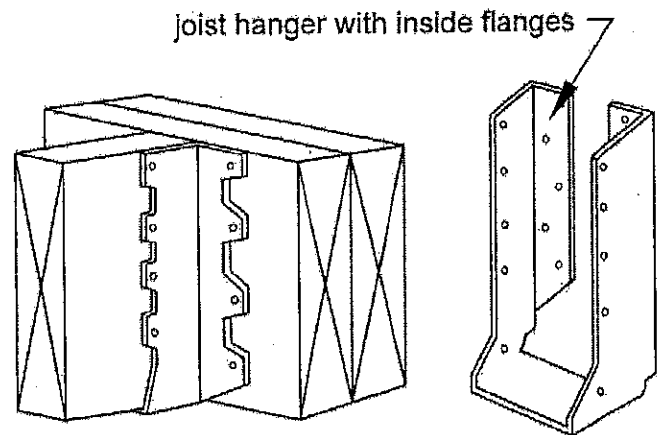

Table 3A: Joist Hanger Download Capacity

Joist Size	Minimum Capacity, lbs
2x8 600	
2x10 700	
2x12 800	

POST REQUIREMENTS

All deck post sizes shall be 6x6 (nominal) or larger, and the maximum height shall be 14'-0" measured to the underside of the beam. Posts shall be centered on footings. Cut ends of posts shall be field treated with an approved preservative (such as copper naphthenate) [R402.1.2]. The beam shall be attached to the post by

notching the 6x6 as shown in Figure 8 or by providing an approved post cap to connect the beam and post as shown in Figure 10. All 3-ply beams shall be connected to the post by a post cap. All thru-bolts shall have washers under the bolt head and nut. Attachment of the beam to the side of the post without notching is prohibited (see Figure 9).

FOOTINGS [R403]

See Figure 12 and Table 4 for footing size, footing thickness, and post attachment options and requirements. All footings shall bear on solid ground and shall be placed at least 12 inches below the undisturbed ground surface or below the frost line, whichever is deeper. Contact the authority having jurisdiction to determine the specified frost line. Bearing conditions shall be verified in the field by the building official prior to placement of concrete. Where the building official determines that in-place soils with an allowable bearing capacity of less than 1,500 psf are likely to be present at the site, the allowable bearing capacity shall be determined by a soils investigation. **DECK FOOTINGS CLOSER THAN 5'-0" TO AN EXISTING EXTERIOR HOUSE WALL MUST BEAR AT THE SAME ELEVATION AS THE FOOTING OF THE EXISTING HOUSE FOUNDATION.**

Do not construct footings over utility lines or enclosed meters. Contact local utilities (call 811) before digging.

Pre-manufactured post anchors shall be galvanized. See MINIMUM REQUIREMENTS.

Table 4. Footing Sizes¹

Beam Span, L _B	Joist Span, L _J	Round Footing Diameter	Square Footing Dimension	Footing Thickness ²
6'	<10'	15"	13"	6"
	<14'	17"	15"	6"
	<18'	20"	18"	7"
8'	<10'	17"	15"	6"
	<14'	20"	18"	8"
	<18'	23"	21"	9"
10'	<10'	19"	17"	7"
	<14'	22"	20"	9"
	<18'	25"	23"	10"
12'	<10'	21"	19"	8"
	<14'	24"	22"	10"
	<18'	28"	26"	11"
14'	<10'	22"	20"	9"
	<14'	26"	24"	11"
	<18'	30"	28"	12"
16'	<10'	24"	22"	9"
	<14'	28"	26"	12"
	<18'	32"	30"	13"
18'	<10'	25"	23"	10"
	<14'	30"	28"	12"
	<18'	34"	32"	14"

1. Assumes 1,500 psf soil bearing capacity.
2. Assumes 2,500 psi compressive strength of concrete. Coordinate footing thickness with post base and anchor requirements.

Figure 12. Typical Footing Options

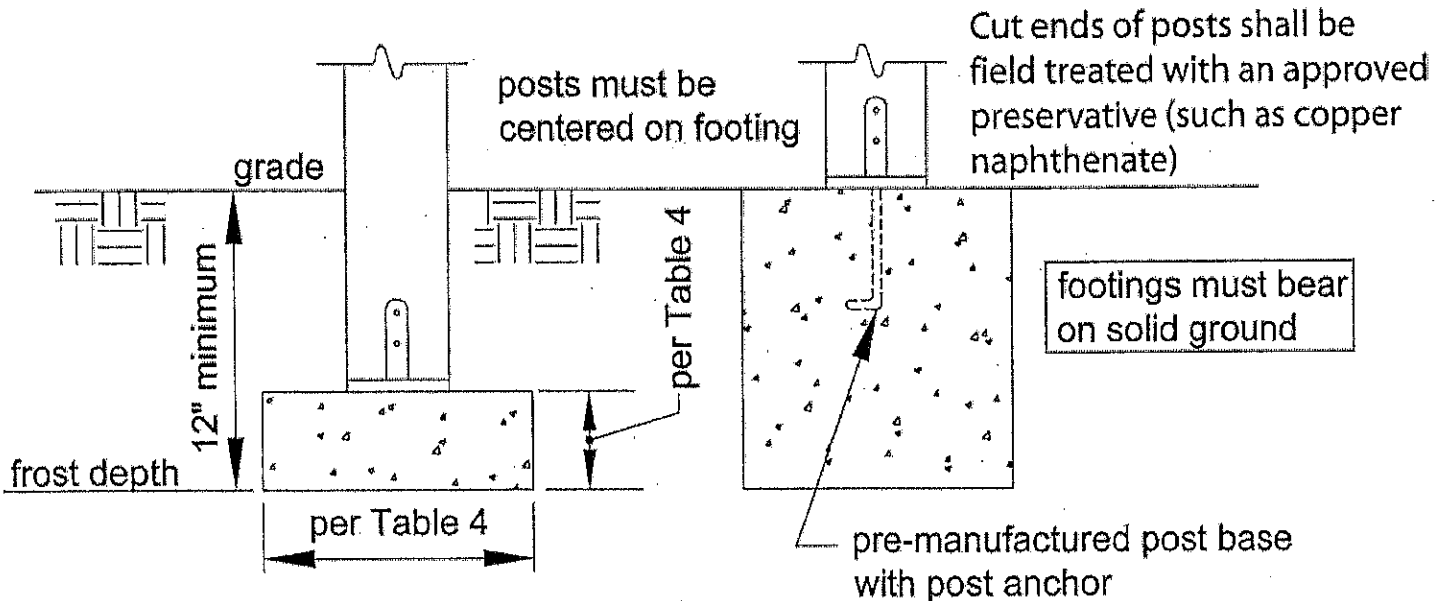

Figure 14. General Attachment of Ledger Board to Band Joist or Rim Board

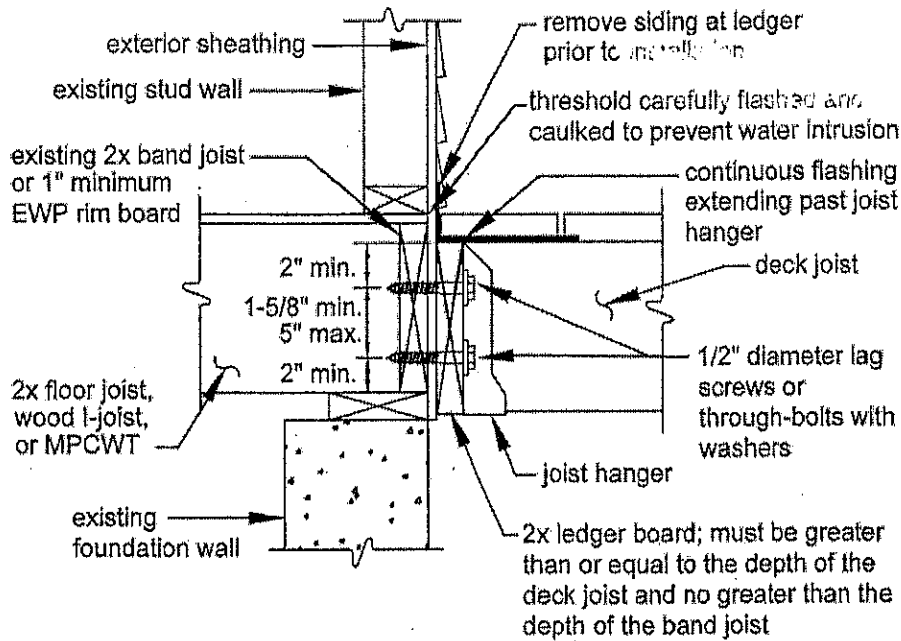

Figure 15. Attachment of Ledger Board to Foundation Wall (Concrete or Solid Masonry)

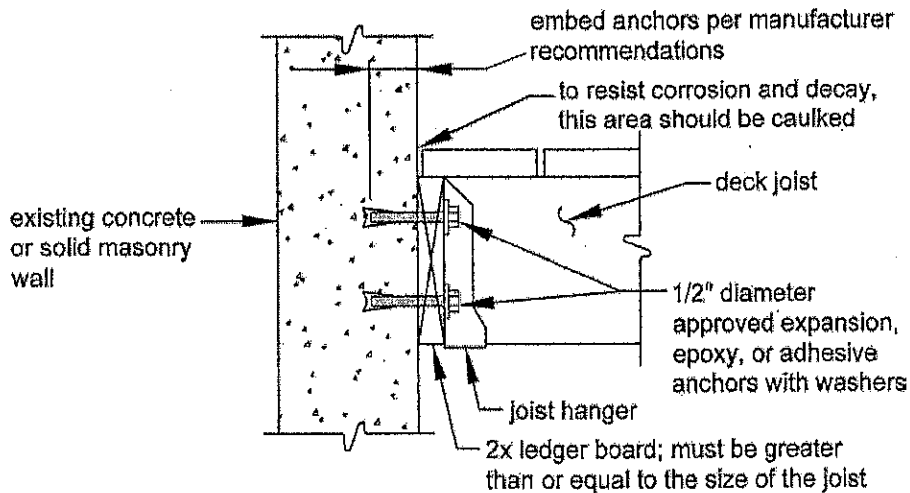
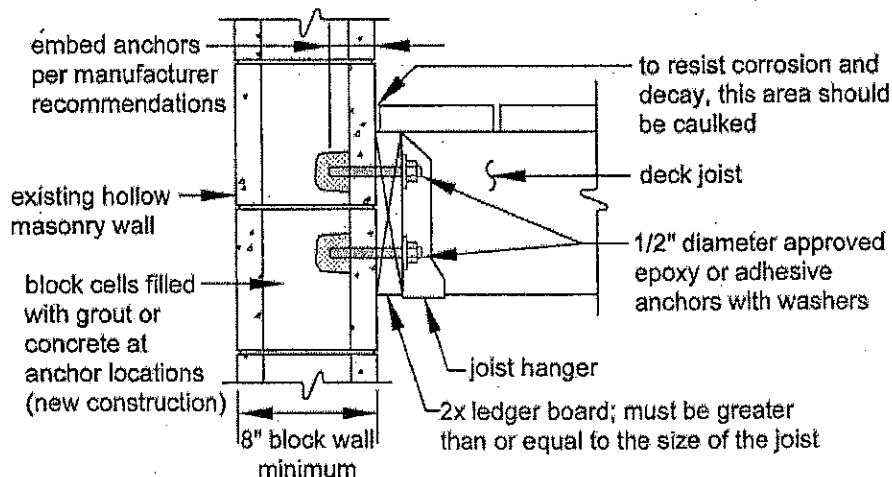

Figure 16. Attachment of Ledger Board to Foundation Wall (Hollow Masonry)



Placement of lag screws or bolts in deck ledgers

The lag screws or bolts shall be placed as shown in Figure 19. The lag screws or bolts shall be staggered from the top to the bottom along the horizontal run of

the deck ledger (see Figure 19). Proper installation of lag screws or bolts shall be verified by the authority having jurisdiction.

Figure 19: Ledger Board Fastener Spacing and Clearances

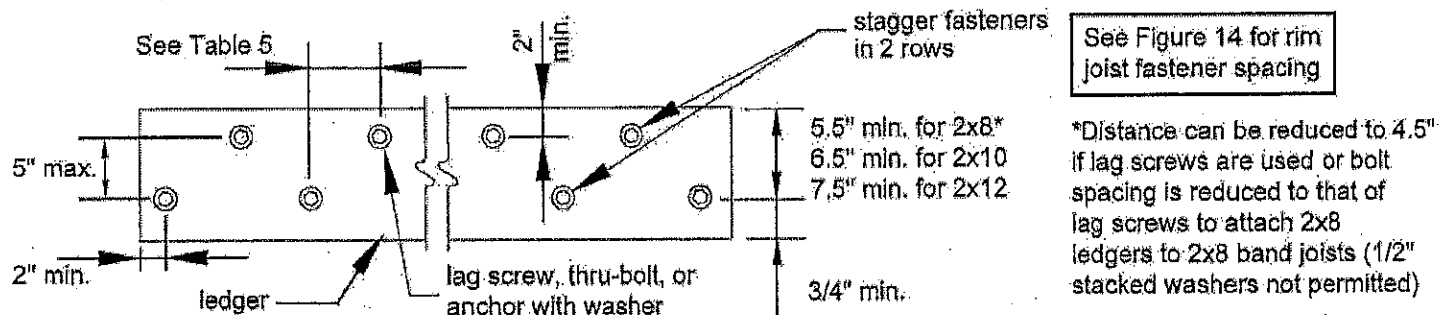

Thru-Bolts

Thru-bolts shall have a diameter of 1/2". Pilot holes for thru-bolts shall be 17/32" to 9/16" in diameter. Thru-bolts require washers at the bolt head and nut.

Expansion and Adhesive Anchors

Use approved expansion or adhesive anchors when attaching a ledger board to a concrete or solid masonry wall as shown in Figure 15 or a hollow masonry wall with a grouted cell as shown in Figure 16. Expansion and adhesive anchor bolts shall have a diameter of 1/2".

Minimum spacing and embedment length shall be per the manufacturer's recommendations. All anchors must have washers.

Lag Screws

Lag screws shall have a diameter of 1/2" (see MINIMUM REQUIREMENTS). Lag screws may be used only when the field conditions conform to those shown in Figure 14. See Figure 20 for lag screw length and shank requirements. All lag screws shall be installed with washers.

Figure 20: Lag Screw Requirements

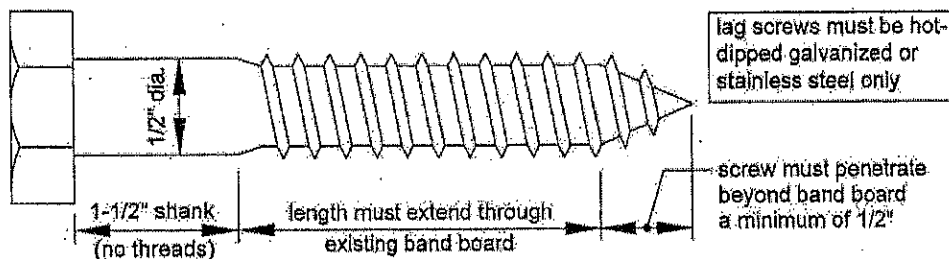

Lag screw installation requirements: Each lag screw shall have pilot holes drilled as follows: 1) Drill a 1/2" diameter hole in the ledger board, 2) Drill a 5/16" diameter hole into the band board of the existing house. **DO NOT DRILL A 1/2" DIAMETER HOLE INTO THE BAND BOARD.**

The threaded portion of the lag screw shall be inserted into the pilot hole by turning. **DO NOT DRIVE LAG SCREWS WITH A HAMMER.** Use soap or a wood-compatible lubricant as required to facilitate tightening. Each lag screw shall be thoroughly tightened (snug but not over-tightened to avoid wood damage).

Diagonal Bracing: Provide diagonal bracing both parallel and perpendicular to the beam at each post as shown in Figure 22. When parallel to the beam, the bracing shall be bolted to the post at one end and beam at the other. When perpendicular to the beam, the bracing shall be bolted to the post at one end and a joist or blocking between joists at the other. When a joist does not align with the bracing location, provide blocking between the adjacent joists. Decks attached to the house as shown in Figure 23A do not require diagonal bracing perpendicular to the house. Diagonal bracing parallel to the house may be omitted at the beam adjacent to the house for a free-standing deck attached as shown in Figure 23.

Free-standing Deck - Attachment to House: Attach the deck rim joist to the existing house exterior wall as shown in Figure 23 for a free-standing deck. The wall must be sheathed with minimum $\frac{3}{8}$ " wood structural panel sheathing. Use lag screws or thru-bolts when fastening to an existing band joist or wall stud; use expansion anchors or epoxy anchors when fastening to

concrete or masonry. DO NOT ATTACH TO BRICK VENEERS. VERIFY THIS CONDITION IN THE FIELD PRIOR TO UTILIZING THIS METHOD. Fasteners shall be 16" on center and staggered in 2 rows for free-standing decks. Flashing over the rim joist is required and must be installed in accordance with the flashing provisions in the LEDGER ATTACHMENT REQUIREMENTS.

Deck Supported by Ledger - Attachment to House: Where supported by attachment to an exterior wall (Figures 14, 15, or 16), decks shall be positively anchored to the primary structure and designed for both vertical and lateral loads as applicable [R502.2.2]. The lateral load connection required shall be permitted to be in accordance with Figure 23A. Hold down tension devices shall be provided in not less than two locations per deck, and each device shall have an allowable stress design capacity of not less than 1,500 lb [R502.2.2.3]. See the *Commentary* to this document for additional information on applicability of this provision.

Figure 23. Attachment of Free-Standing Deck to House for Deck Stability

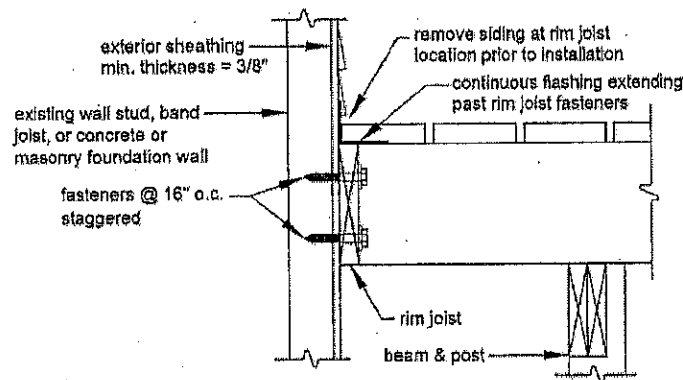
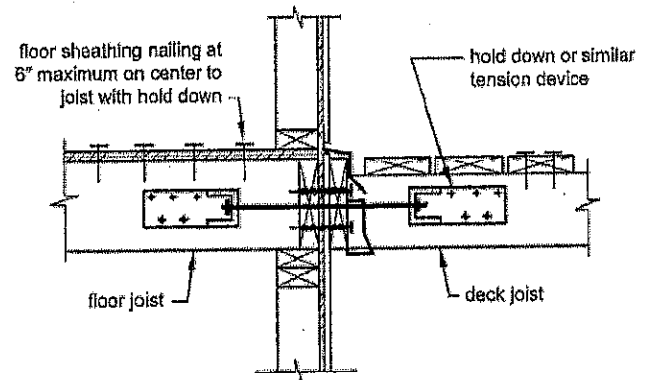

Figure 23A. Example of a Lateral Load Device for a Deck Attached to a House with a Ledger



GUARD REQUIREMENTS

All decks greater than 30" above grade are required to have a guard [R312.1] - one example is shown in Figure

24. Other methods and materials may be used for guard construction when approved by the authority having jurisdiction.

Figure 24. Example Guard Detail

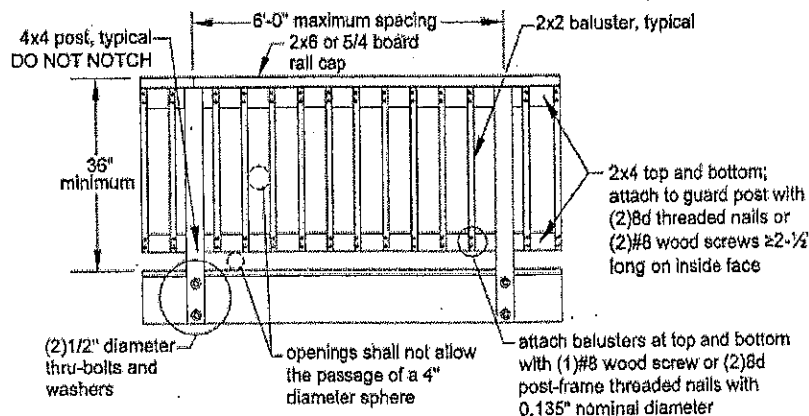

STAIR REQUIREMENTS

Stairs, stair stringers, and stair guards shall meet the requirements shown in Figure 27 through Figure 34 and Table 6 except where amended by the local jurisdiction. All stringers shall be a minimum of 2x12. Stair stringers shall not span more than the dimensions shown in Figure 28. If the stringer span exceeds these dimensions, then a 4x4 post may be provided to support the stringer and shorten its span length. The 4x4 post shall be notched and bolted to the stringer with (2) 1/2" diameter through-bolts with washers per Figure 8. The post shall be centered on a 12" diameter or 10" square, 6" thick footing. The footing shall be constructed as shown in Figure 34 and attached to the post as shown in Figure 12. An intermediate landing may also be provided to shorten

the stringer span (see provisions below). If the total vertical height of a stairway exceeds 12'-0", then an intermediate landing shall be required. All intermediate stair landings must be designed and constructed as a free-standing deck using the details in this document. Stairs shall be a minimum of 36" in width as shown in Figure 33 [R311.7]. If only cut stringers are used, a minimum of three are required. For stairs greater than 36" in width, a combination of cut and solid stringers can be used, but shall be placed at a maximum spacing of 18" on center (see Figure 29). The width of each landing shall not be less than the width of the stairway served. Every landing shall have a minimum dimension of 36" measured in the direction of travel and no less than the width of the stairway served [R311.7].

Figure 27. Tread and Riser Detail

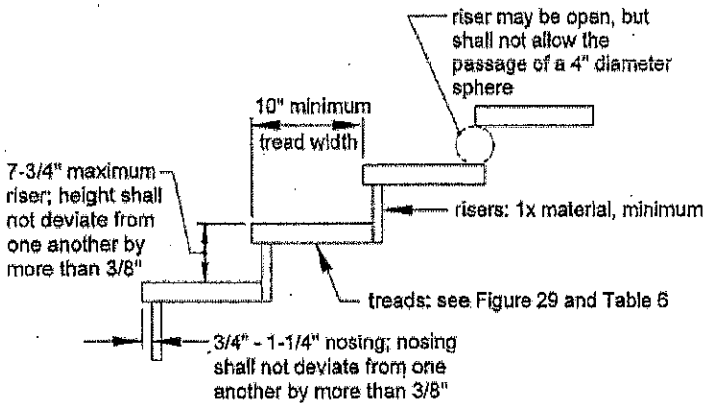

Figure 28. Stair Stringer Requirements

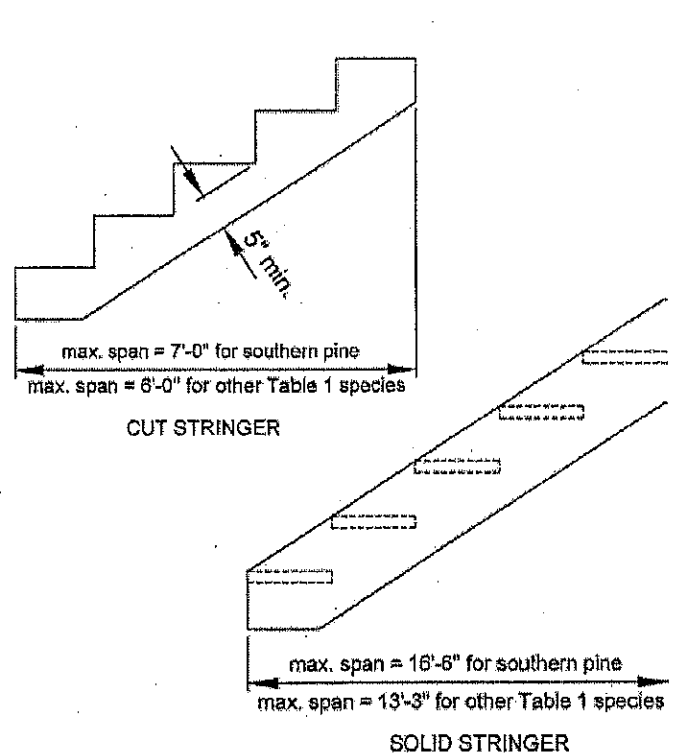

Figure 29. Tread Connection Requirements

Attachment per tread at each stringer or ledger:
 2x_ or 5/4 treads - (2)#8d threaded nails or (2)#8 screws ≥2-1/2" long
 3x_ treads - (2)16d threaded nails or (2)#8 screws ≥3-1/2" long

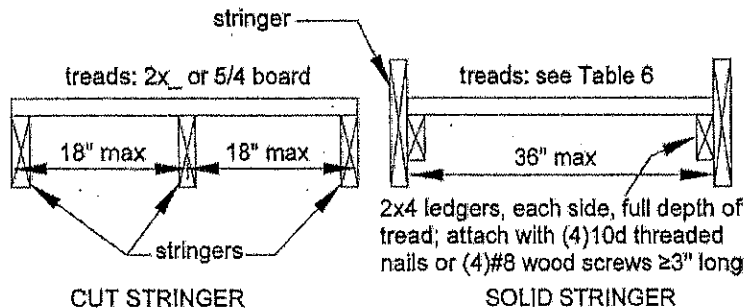

Table 6. Minimum Tread Size for Cut and Solid Stringers¹

Species	Cut Stringer	Solid Stringer
Southern Pine	2x4 or 5/4	2x6
Douglas Fir Larch, Hem-Fir, SPF ²	2x4 or 5/4	2x8 or 3x4
Redwood, Western Cedars, Ponderosa Pine ³ , Red Pine ³	2x4 or 5/4	2x10 or 3x4

1. Assumes 300 lb concentrated load, L/288 deflection limit, No. 2 grade, and wet service conditions.
 2. Incising assumed for refractory species including Douglas fir-larch, hem-fir, and spruce-pine-fir.
 3. Design values based on northern species with no incising assumed.

STAIR FOOTING REQUIREMENTS [R403]

Where the stairway meets grade, attach the stringers to the stair guard posts as shown in Figure 34. Posts shall bear on footings. All footings shall bear on solid ground and shall be placed at least 12 inches below the undisturbed ground surface or below the frost line, whichever is deeper (see Figure 34). Stringers shall bear on a 2x4 bearing block attached to the post as shown. Stringers shall not bear on new or existing concrete pads or patios that are not founded below this depth. When guards are not required (see GUARD

REQUIREMENTS), posts may terminate below the bottom tread elevation. Bolts are only required if a guard post is required.

STAIR LIGHTING REQUIREMENTS [R303.6]

Stairways shall have a light source located at the top landing such that all stairs and landings are illuminated. The light switch shall be operated from inside the house. However, motion detected or timed switches are acceptable.

Figure 33. Miscellaneous Stair Requirements

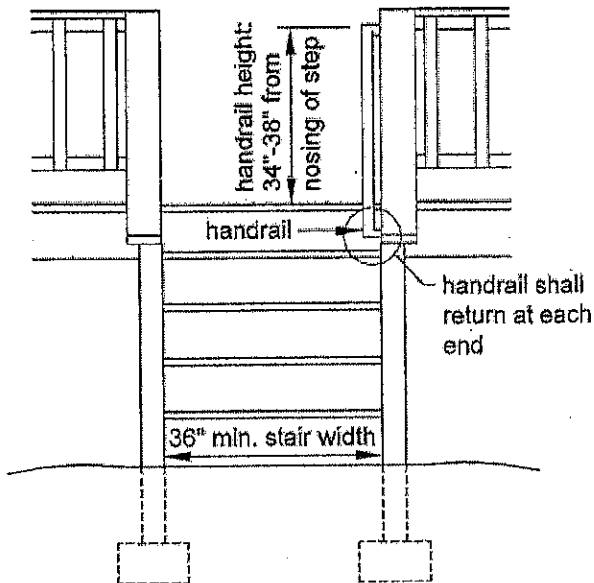
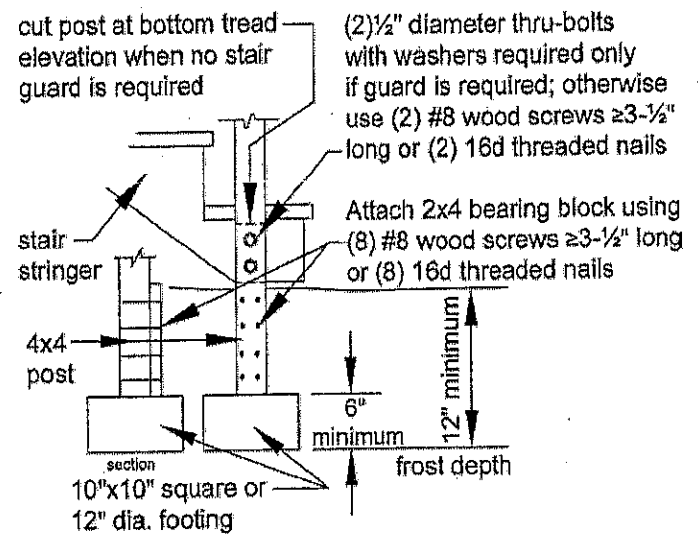

Figure 34. Stair Footing Detail



FRAMING AT CHIMNEY OR BAY WINDOW

All members at a chimney or bay window shall be framed in accordance with Figure 35. Headers may span a maximum of 6'-0". When a chimney or bay window is wider than 6'-0", one or more 6x6 posts may be added to reduce header spans to less than 6'-0". In such cases, the post footing must meet the requirements in the FOOTINGS section. Headers with a span length greater than 6'-0" require a plan submission. Headers shall be located no more than 3'-0" from the end of the trimmer joist.

Triple trimmer joists are required on each side of the header if joist spacing is 12" or 16" o.c. or if the trimmer joist span exceeds 8'-6"; otherwise, double trimmer joists are permitted. Trimmer joists may bear on the beam and extend past the beam centerline up to L/4 as shown in Figures 1A and 2, or the trimmer joist may attach to the side of the beam with joist hangers as shown in Figure

1B. Joist hangers shall each have a minimum download capacity in accordance with Table 7. Bolts or lag screws used to attach the hanger to the ledger shall fully extend through the ledger into the 2-inch nominal lumber band joist (1-1/2" actual) or EWP rim board. Otherwise a freestanding deck is required.

Table 7. Trimmer Joist Hanger Download Capacity

Joist Size	Minimum Capacity, lbs
2x8	1050
2x10	1380
2x12	1500

Commentary to Prescriptive Residential Wood Deck Construction Guide DCA 6



Foreword

This *Commentary to DCA 6 – Prescriptive Residential Wood Deck Construction Guide* has been requested by builders, building officials, and others, to provide background information and example calculations for various sections and tables of *DCA 6*.

The *DCA 6 Commentary* follows the same organization as *DCA 6*. Discussion of a particular provision in *DCA 6* is found in the *DCA 6 Commentary* by locating the same section or subsection found in *DCA 6*. Not every section of *DCA 6* has a corresponding commentary section. The *DCA 6 Commentary* provides background information intended to give the reader an understanding of the data and/or experience upon which the provision is based. One or more examples of the calculation procedures used to produce several of the tables are given to illustrate the scope of conditions covered by the table.

The provisions of *DCA 6* come primarily from the International Code Council's *International Residential Code (IRC)*. In developing the *DCA 6 Commentary*, data available from laboratory tests and experience with structures in-service was analyzed and evaluated for the purpose of providing a consistent explanation. It is intended that this document be used in conjunction with competent design, accurate fabrication, and adequate supervision of construction. Therefore, AF&PA does not assume any responsibility for errors or omissions in the *DCA 6 Commentary*, nor for designs or plans prepared from it.

Inquiries, comments, and suggestions from readers of this document are invited.

American Forest & Paper Association

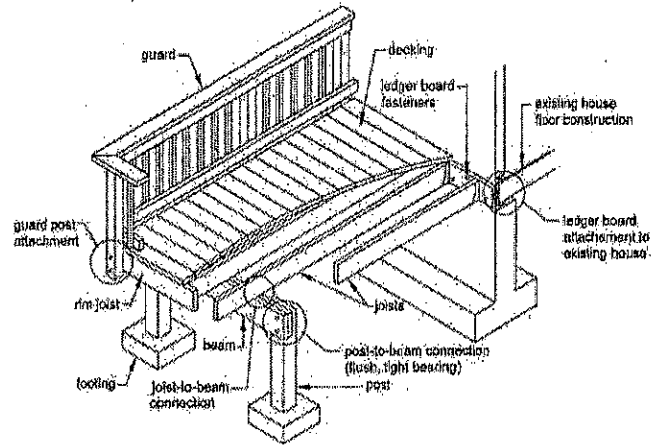

Background

In August 2006, the American Forest & Paper Association's American Wood Council (AWC) Technical Committee formed an ad-hoc task group to address prescriptive provisions for residential wood deck construction. Representatives of the wood products industry, home builders, connector manufacturers, building officials, and truss industry were represented on the task group.

The Technical Committee urged the Task Group not to "reinvent the wheel," but to review existing information to determine if there was something on which to build. One resource reviewed was a document developed by the Fairfax County, Virginia Department of Public Works and Environmental Services titled "Typical Deck Details." With Fairfax County's permission, this became the basis for *DCA 6*.

Since Fairfax County's *Typical Deck Details* was developed for a specific geographic location, *DCA 6* was expanded to apply on a national basis (e.g. addition of western lumber species). The first version of *DCA 6* was posted to the AWC website in October 2007.

The *IRC* provides guidance on applicability of provisions of the *IRC* for high wind and seismic regions as follows:

“R301.2.1.1 Design criteria. Construction in regions where the basic wind speeds from Figure R301.2(4) equal or exceed 100 miles per hour in hurricane-prone regions, or 110 miles per hour elsewhere, shall be designed in accordance with one of the following:...” Several alternate methodologies are subsequently listed. This indicates that provisions of the *IRC* are applicable in hurricane regions less than 100 mph and less than 110 mph elsewhere.

“R301.2.2 Seismic provisions. The seismic provisions of this code shall apply to buildings constructed in Seismic Design Categories C, D₀, D₁ and D₂, as determined in accordance with this section...

Exception: Detached one- and two-family dwellings located in Seismic Design Category C are exempt from the seismic requirements of this code.”

DECKING REQUIREMENTS

The American Lumber Standard Committee (ALSC) *Policy for Evaluation of Recommended Spans for Span Rated Decking Products* (ALSC Decking Policy) provides a uniform method for assessing span rated decking products which are produced from many different species of wood, and graded under several different grading standards. This ALSC policy covers specific products classified by size as decking and are assigned a recommended span of usually 16" or 24". This policy is not intended to be used for the assessment or approval of decking spans in excess of 24". The range of current grading rule specifications and species requires the establishment of a uniform common analytical procedure for assessing the appropriateness of these products relative to the recommended spans. This ALSC policy establishes this uniform analytical procedure.

The analysis for maximum span rating assumes the following design conditions:

1. Span – Two-span continuous with load applied to only one span.
2. Seasoning – Green use condition (Moisture Content >19%), assumed to be 23% MC or greater.

8. *IRC* R703.8(5) requires attachment of flashing “...Where exterior porches, decks, or stairs attach to a wall or floor assembly of wood-frame construction.” Aluminum flashing should not be used if it will be in contact with treated lumber. Lumber treated with preservatives such as alkaline copper quat (ACQ), copper azole (CA), or ammoniacal copper zinc arsenate (ACZA) all contain copper. As a result, they will corrode aluminum flashing as well as ferrous metals.

9. *IRC* R110.1 Use and occupancy states: “No building or structure shall be used or occupied...until the building official has issued a certificate of occupancy...”

10. See Commentary for **Alternative Methods and Materials**.

3. Deflection Limit – Deflection under design loads using calculated average allowable modulus of elasticity shall not exceed $L/180$.

Load Conditions – Allowable span analysis includes the following two load conditions with load applied on one span of a two-span continuous beam:

- a. Uniform Load – the calculated maximum allowable fiber stress in bending derived from *ASTM D2555* and *D245*, or the In-grade test procedures of Annex 1 (of ALSC Decking Policy) equals or exceeds the stress induced by a 70 psf uniform load on the recommended span. The analysis assumes normal load duration.
- b. Point Load – the calculated maximum allowable fiber stress in bending derived from *ASTM D2555* and *D245*, or the In-grade test procedures of Annex 1 (of ALSC Decking Policy) equals or exceeds the stress induced by a 220 lb. point load applied at the midpoint of the recommended span. The analysis assumes 7-day load duration.

See Commentary for **Alternative Methods and Materials** for decking materials not covered by the ALSC policy

DECK FRAMING PLAN

A framing plan shows the layout of the primary structural system. Examples of structural elements include: joists, beams, ledger board, posts, footings, stringers, treads, and the type, size, and spacing of ledger board fasteners. Figure C5 shows an example of a typical deck framing plan.

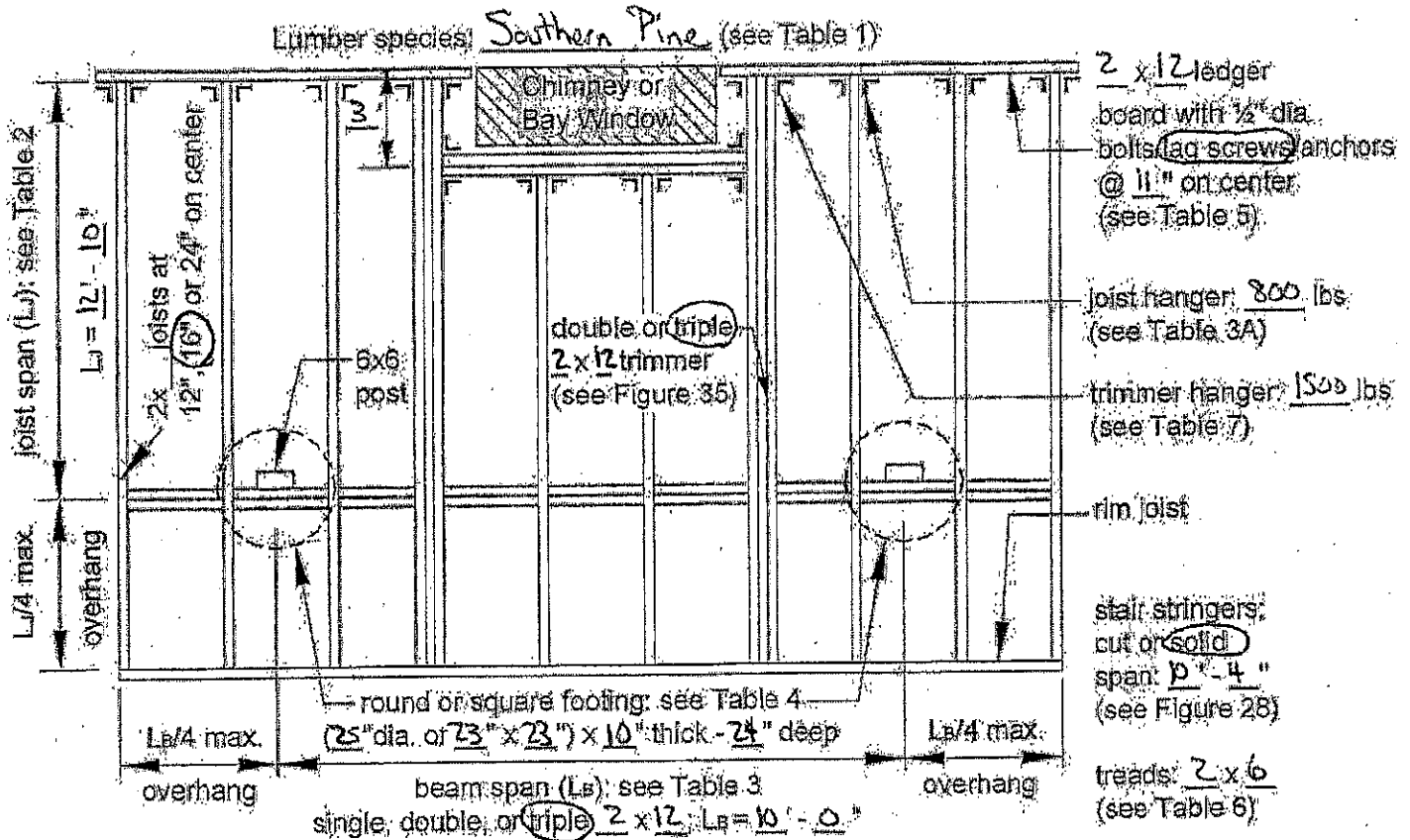

Figure C5. Example of Typical Deck Framing Plan

JOIST-TO-BEAM CONNECTION

Joist-to-beam connections must be installed to handle forces in several directions. Options 1 and 2 handle gravity loads through bearing of the joist to the beam, while Option 3 requires nails to resist these downward loads. All three options have been evaluated to ensure

that an uplift load created by a 220 lb point load at the end of a cantilevered joist will be resisted.

Manufacturers regard connectors with missing nails as mis-installations and do not recommend they be installed as such.

JOIST HANGERS

The loads listed in the Table 3A are derived from the worst case condition for each joist size based on Table 2 (508 lbs, 654 lbs, and 771 lbs for southern pine at 24" o.c. for 2x8, 2x10, and 2x12, respectively). For simple

span applications without overhangs, as shown in Table 2, note that spans are identical to those shown in Table 2 with overhangs for southern pine joists at 24" o.c., therefore the same joist hanger capacities as shown in Table 3A will work for spans with or without overhangs.

Table C4 shows additional footing diameters and thicknesses for joist spans not shown in Table 4.

Coordinating the footing thickness with post base and anchor requirements means ensuring that post anchor length does not exceed the thickness of the footing.

Table C4. Footing Sizes¹

Beam Span L _B	Joist Span L _J	Round Footing Diameter	Square Footing Dimension	Footing Thickness ²
6'	<8'	13"	11"	6"
	<12'	16"	14"	6"
	<16'	19"	17"	7"
8'	<8'	15"	13"	6"
	<12'	19"	17"	7"
	<16'	21"	19"	8"
10'	<8'	17"	15"	6"
	<12'	21"	19"	8"
	<16'	24"	22"	9"
12'	<8'	19"	17"	7"
	<12'	23"	21"	9"
	<16'	26"	24"	11"
14'	<8'	20"	18"	8"
	<12'	24"	22"	10"
	<16'	28"	26"	12"
16'	<8'	21"	19"	8"
	<12'	26"	24"	11"
	<16'	30"	28"	13"
18'	<8'	23"	21"	9"
	<12'	28"	26"	11"
	<16'	32"	30"	13"

1. Assumes 1,500 psf soil bearing capacity.
2. Assumes 2,500 psi compressive strength of concrete. Coordinate footing thickness with post base and anchor requirements.

LEDGER ATTACHMENT REQUIREMENTS

According to *IRC* R311.3.1, the distance from the top of the threshold to the top of deck boards cannot exceed 1-1/2". If a door does not swing over the landing or deck, the step-down can be up to 7-3/4". The ledger can be lowered for improved drainage, subject to meeting maximum step-down heights for accessibility and means of egress, edge distance and spacing requirements, and shear design at connection requirements of *NDS* 3.4.3.3(a).

The basis for edge distances and spacing between rows (Figure 19) is *NDS* Tables 11.5.1A and 11.5.1D, respectively, for perpendicular to grain conditions. Per *NDS* Table 11.5.1A, edge distance is 4D (where D is fastener diameter) for the loaded edge. For 1/2" diameter bolts, 4D = 2" edge distance.

Per *NDS* Table 11.5.1D, spacing between rows is based on the l/d ratio of the fastener. For a 1-1/2" ledger and rim board, $l/d = 1-1/2" / 1/2" = 3$ and the minimum spacing is $(5l + 10D) / 8 = 1-9/16"$ – this is rounded up to 1-5/8". Per footnote 2 of *NDS* Table 11.5.1D, the maximum spacing between fasteners is 5". This requirement is based on potential shrinkage of the ledger which could create tension perpendicular to grain stresses if the outer edges of the ledger are constrained by bolts.

DECK STABILITY

The requirement for diagonal bracing when a deck is greater than 2 feet above grade is applicable to both free-standing decks and decks supported by a ledger.

If the deck is attached to the house as shown in Figures 14, 15, 16, or 23, an alternative to knee braces for deck stability (Figure 22) is installation of decking at a 45 degree angle to the deck joists. Decks are stiffer laterally with diagonally oriented lumber decking versus decking installed perpendicular to joists.

With respect to hold down tension devices, *IRC* R502.2.2 requires anchorage to the primary structure for both vertical and lateral loads as applicable. Further, the *IRC* includes hold down tension devices as a prescriptive means to achieve compliance with the lateral load connection requirements without requiring engineering. Figure 23A was taken directly from the *FEMA Home Builder's Guide to Seismic Resistant Construction*

(FEMA 232) which refers to it as an “above-code recommendation.” In lieu of the prescriptive hold down tension device specified, an alternate engineered connection detail is permitted or the deck can be designed to be free-standing.

While Item 7 of *DCA 6* Minimum Requirements states that the document does not address wind or seismic design issues, some interpret R502.2.2 to be applicable in all cases since lateral loads can be developed by other sources including people moving or dancing on a deck. Another interpretation is that the term “as applicable” in R502.2.2 means the provision is only required for code prescribed loads. The only code prescribed lateral loads are wind and seismic.

Where deck joists are perpendicular to the house floor joists, blocking between house joists and boundary nailing of the house floor diaphragm to the blocking is required.

GUARD REQUIREMENTS

Figure 24 requires that openings not allow the passage of a 4" diameter sphere. However, it does not address openings underneath a fixed deck bench used in place of guards. All openings, including those underneath benches used in place of guards, shall not allow the passage of a 4" diameter sphere.

Additionally, if fixed seating is adjacent to guards, the guard height should be measured from the seat rather than the deck surface. This will help minimize exposure

to falls over the top of the guard due to individuals standing on deck seats.

IRC Table R301.5 requires guard in-fill components (all those except the handrail), balusters, and panel fillers to be designed to withstand a horizontally applied normal load of 50 pounds on an area equal to 1 square foot. This load need not be assumed to act concurrently with any other live load requirement. Baluster connection requirements shown in Figure 24 have been designed to resist that load.

GUARD POST ATTACHMENTS

Both the *IRC* and *International Building Code (IBC)* specify that guardrails and handrails be capable of resisting a minimum concentrated live load of 200 lbs applied in any direction. Commonly used residential guardrail post connections were laboratory tested at the required load level for a code-conforming assembly per the *IBC* (Loferski et al., 2006). A commercially available connector, typically used in shear wall construction, was tested in a post-to-deck residential guardrail assembly. The connection passed a load test based on code provisions for a “tested assembly.” Connection details in Figures 25 and 26 reflect these test results.

A minimum requirement of 1,800 lbs for the hold down connector ensures adequate capacity (Loferski et al., 2005) for a 36" maximum rail height. A higher rail height requires design of a higher capacity connector. Manufacturers' tabulated values for hold down connectors typically include a load duration (C_D) increase of 60% since connectors for shear walls are used to resist wind and seismic loads. The 200 lbs concentrated load requirement for guard rails is assumed to be a 10 minute load duration (e.g. it would not see a maximum 200 lbs outward load for more than 10 minutes cumulatively in its lifetime). Therefore, $C_D=1.6$ is used for hold downs in this application.

This section requires deck guard posts to be at least 4x4 nominal with a reference bending design value not less than 1,100 psi to ensure sufficient bending stress in the post. Assuming the lever arm is 39.5" (36" + 1.5" deck board + 2" edge distance), the bending moment is 39.5" x 200 lbs = 7,900 in-lbs. Bending stress, f_b , is calculated as follows:

$$M/S_{(4x4)} = 7,900 \text{ in-lbs} / 7.146 \text{ in}^3 = 1,106 \text{ psi.}$$

No. 2 grades of all Table 2 species meet this requirement with the following assumptions. The adjusted bending design value, F'_b , is based on a wet service factor, $C_M = 0.85$, and incising factor, $C_i = 0.80$ (Douglas fir-larch, hem-fir, spruce-pine-fir). A load duration factor, $C_D = 1.6$, is assumed for consistency with the hold down device used to connect the guard to the joist.

Figures 25 and 26 show minimum and maximum spacing requirements for bolts in deck joists and deck rim boards. The 5" maximum spacing is per footnote 2 of *NDS* Table 11.5.1D. This requirement is based on potential shrinkage of the joist or rim board which could create tension perpendicular to grain stresses if the outer edges of the deck joist or rim are constrained by bolts.

Table C7a. Maximum Distance “a” from Trimmer Joist End to a Point where a 6’ Header Frames into a 2-ply Trimmer Joist.

Species	Trimmer	Size	a _{max}
Southern Pine		2-2x8	18"
		2-2x10	24"
		2-2x12	29"
Douglas Fir-Larch, Hem-Fir, SPF ¹		2-2x8	14"
		2-2x10	16"
		2-2x12	19"
Redwood, Western Cedars, Ponderosa Pine ² , Red Pine ²		2-2x8	14"
		2-2x10	16"
		2-2x12	18"

1. Incising assumed for refractory species including Douglas fir-larch, hem-fir, and spruce-pine-fir.
2. Design values based on northern species with no incising assumed.

The trimmer hanger capacities listed in Table 7 are based on southern pine joist spans at 12" o.c. or 16" o.c. spacing (whichever controls). The reaction is a combination of the concentrated header load P_b/L_j and the tributary uniform load between the trimmer and the next adjacent joist. Another way of tabulating trimmer hanger capacities is shown in Table C7c based on trimmer spans. Linear interpolation of tabulated values is permitted.

Trimmer Joist Span Limited by Concentrated Load on the Ledger

Bolts or lag screws used to attach the trimmer hanger to the ledger are required to fully extend through the ledger into the band joist or rim board. If a typical face mounted hanger is installed where only nails are used to attach the hanger to the ledger, the ledger would carry a large portion of the load. Since a concentrated load would be created on the ledger, it would be resisted by the bolts at the end of the ledger. As discussed under **LEDGER ATTACHMENT REQUIREMENTS**, the provisions for minimum distance, d_e , between the top of the ledger and the bottom row of fasteners (Figure 19) is based on *NDS* 3.4.3.3(a) for shear design at connections. Based on this analysis, trimmer joist lengths would need to be limited to the maximum trimmer joist spans shown in Table C7b, regardless of the trimmer joist species or number of plies. Since this analysis is based on a simple span trimmer joist, a trimmer joist with an overhang of up to $L_j/4$ would be conservative. The load on the end of the cantilever would reduce the reaction at the ledger.

Table C7b. Maximum Trimmer Joist Span (L_j) Based on Distance “a” from the Trimmer Joist End to the Point where the Header Frames into the Trimmer.^{1,4}

Ledger Species	Size	a = 1'	a = 2'	a = 3'
Southern Pine	2x8	5'-9"	7'-5"	8'-11"
	2x10	9'-2"	10'-11"	12'-7"
	2x12	9'-5"	11'-2"	12'-10"
Douglas Fir-Larch, Hem-Fir, Spruce-Pine-Fir ²	2x8	4'-6"	6'-0"	7'-6"
	2x10	6'-10"	8'-6"	10'-1"
	2x12	7'-0"	8'-9"	10'-4"
Ponderosa Pine ³ , Red Pine ³ , Redwood,	2x8	4'-3"	5'-9"	7'-3"
	2x10	6'-5"	8'-1"	9'-8"
Western Cedar	2x12	6'-7"	8'-3"	9'-10"

1. Assumes 6' header span. See Figure 35 for header, trimmer, and ledger framing details.
2. Incising assumed for refractory species including Douglas fir-larch, hem-fir, and spruce-pine-fir.
3. Design values based on northern species with no incising assumed.
4. Shading indicates where triple trimmers are required. See text for alternate 2-ply trimmer conditions.

Table C7c. Trimmer Joist Hanger Download Capacity Based on Trimmer Span.

Trimmer Span	Minimum Capacity, lbs
8'	660
10'	860
12'	1060
14'	1260
16'	1460
18'	1500

Examples

1) Assume a 2x10 redwood joist spanning 12'-0" at 16" o.c. (per Table 2) framing around a 5' wide by 2.5' deep chimney. Set a 6' header 3' from the end of the trimmer joist. A triple trimmer joist is required since the span exceeds 8'-6". If the trimmer hanger does not attach through the ledger to the rim board or band joist, the trimmer joist span is limited to 9'-8" per Table C7b.

Several solutions exist:

- Reduce all joist spans to 9'-8".
- $L_j/4 = 2'-5"$ so $L_j + L_j/4 = 12'-1"$ total joist length, which would provide the same square footage.
- Place a post under the center of the header to reduce the header span.

APPENDIX

SAFETY GLAZING REQUIREMENTS: IRC

R308.4 states that safety glazing in window glass is required when the existing house wall acts as a barrier to adjacent stairs, landings, and areas at the top and bottom of stairs. If a window or portion thereof falls within the area shown in Figure A1, glass panes within that area should be safety glazed. Safety glazing should reduce injury due to accidental impact when ascending or descending stairs. Application of safety glazing film to glass that was not originally treated is acceptable to meet this requirement.

Exceptions to this requirement include:

- When a protective bar is installed on the accessible side(s) of the glazing $36" \pm 2"$ above the deck surface. The bar shall be capable of withstanding a horizontal load of 50 plf without contacting the glass and be a minimum of $1\frac{1}{2}"$ in height.
- The side of a stairway, landing, or ramp has a guardrail or handrail, including balusters or in-fill panels, complying with the provisions of Sections R311.7.6 and R312 and the plane of the glass is more than 18" from the railing.
- When a solid wall or panel extends from the plane of the adjacent walking surface to 34" - 36" above the floor and the construction at the top of that wall or panel is capable of withstanding the same horizontal load as the protective bar.

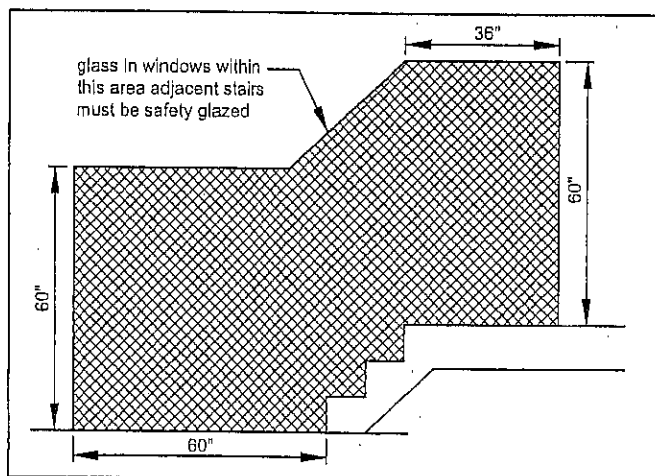

Figure A1. Safety glazing requirements.

